

## FUZZY FINITE ELEMENT METHOD AND ITS APPLICATION

**B. Möller\*, M. Beer, W. Graf and J.-U. Sickert**

*Department of Civil Engineering, Institute of Structural Analysis*

*Dresden University of Technology, Dresden, Germany*

*E-mail: statik@rcs.urz.tu-dresden.de*

*web page: <http://rcswww.urz.tu-dresden.de/~statik/htmlhome/homest.html>*

**Abstract:** In the Fuzzy Finite Element Method (FFEM) uncertain geometrical, material and loading parameters are treated as fuzzy values. Uncertainties of the characteristic fuzziness may be observed, e.g. in earthquake loading, impact loads, storm loading, terrorist attacks, damage processes or shortcomings in construction work. Spatially distributed uncertainties are described in the method of finite elements using fuzzy functions. These fuzzy functions describe a bunch of functions with uncertain bunch parameters. The introduced fuzzy functions enable fuzziness to be accounted for in the principle of virtual displacements or the particular variational principle adopted. In order to solve the system of fuzzy differential equations and the system of fuzzy equations of the FFEM  $\alpha$ -level optimization is applied. The FFEM approach is demonstrated by way of an application example.

**Key words:** Fuzzy finite element method (FFEM), fuzzy function,  $\alpha$ -level optimization

### 1 REMARKS ON UNCERTAINTY

The uncertainty of data and information may be characterized by randomness, fuzziness or fuzzy-randomness; it is also possible to distinguish between stochastic and non-stochastic uncertainty. The property randomness is linked to specific preconditions: in particular, all elements of a sample must be generated under constant reproduction conditions. Informal and lexical uncertainty as well as uncertainty associated with human error and expert knowledge, on the other hand, possess the property fuzziness. These forms of uncertainty may be observed, e.g. in earthquake loading, impact loads, storm loading, terrorist attacks, damage and aging processes or shortcomings in construction work.

In finite element analysis geometrical, material and loading data as well as model parameters may possess uncertainty. If sufficiently reliable stochastic data are not available, their uncertainty may be modeled by fuzziness. When specifying fuzziness, both objective and subjective information is taken into consideration.

In contrast to the latter, fuzzy-randomness is exhibited by data material possessing partly random properties, whose derived random parameters cannot be modeled with absolute certainty. Fuzzy-randomness combines randomness and fuzziness and is specified by means of fuzzy probability distribution functions. Fuzzy-randomness may arise, e.g. in the following context: the stochastic data material exhibits fuzziness, i.e. the sample values have doubtful accuracy or were obtained under unknown or non-constant reproduction conditions.

It is presupposed in the following developed fuzzy finite element method that the uncertainty may be specified as fuzziness.

## 2 MODELING OF UNCERTAINTY WITH FUZZY FUNCTIONS

Physical parameters possessing fuzziness with regard to external loading or material, geometrical and model parameters may occur at all points of a structure. Depending on the dimensionality of the structure -  $\mathbb{R}^1$  bar structures,  $\mathbb{R}^2$  plane structures,  $\mathbb{R}^3$  3-D structures - it is proposed to describe fuzziness using fuzzy functions.

Fuzzy functions may describe uncertainty in different ways<sup>1</sup>. Starting from a classical function  $f: X \rightarrow Y$ , uncertainty may be present in the argument of the function, e.g. in the form  $f(\tilde{\underline{x}})$ , in the function  $f$  itself, e.g. in the form  $\tilde{f}(\underline{x})$  or simultaneously in the argument and the function itself, e.g. in the form  $\tilde{f}(\tilde{\underline{x}})$ . The symbol  $\sim$  denotes fuzziness.  $f(\tilde{\underline{x}})$  is referred to as the fuzzy extension of non-fuzzy functions and  $\tilde{f}(\underline{x})$  is referred to as a fuzzy function with non-fuzzy arguments.

The form  $\tilde{f}(\underline{x})$  appears to be particularly suitable for describing the fuzziness of physical parameters within the framework of a finite element analysis. To every crisp point  $\underline{x} = \{x_1, x_2, x_3\}$  it is possible to assign an uncertain physical parameter, whose distribution in  $\mathbb{R}^n$  is described by the fuzzy function  $\tilde{f}(\underline{x})$ .

The permissibility of introducing fuzziness, also with regard to the position vector  $\underline{x}$ , requires fuzzy functions of the form  $\tilde{f}(\tilde{\underline{x}})$ . Using  $\tilde{f}(\underline{x})$ , on the other hand, it is only possible to describe uncertain geometrical parameters with restrictions. For structures in  $\mathbb{R}^1$  and  $\mathbb{R}^2$  fuzziness is permitted for the coordinate  $x_3$ . All geometrical parameters dependent on  $x_3$ , such as the thickness of structure elements or level specifications for reinforcement in a cross-section, may be expressed as fuzzy parameters. Fuzzy functions with non-fuzzy arguments may be formulated in two different ways, depending on whether the image of  $\underline{x} \in X$  is a fuzzy set of  $\tilde{y} = \tilde{f}(\underline{x})$  on  $Y$  or whether  $\underline{x}$  is mapped onto  $Y$  using a fuzzy set of functions. In the first case, so-called fuzzifying functions are obtained, whereas in the second case, a fuzzy bunch of functions is obtained. The second form enables the numerical evaluation of the governing finite element equations to be performed using  $\alpha$ -level optimization; this forms the basis of the following considerations.

A fuzzy bunch of functions  $f: X \rightarrow Y$  is a fuzzy set  $\tilde{F}$  on  $Y^X$ , i.e. each function  $f$  from  $X$  to  $Y$  has a membership value  $\mu_{\tilde{F}}(f)$  in  $\tilde{F}$  and is a crisp function, which is referred to as an original. A fuzzy bunch is thus a multi-valued fuzzy relationship, due to the fact that if  $f_1(x)$  and  $f_2(x)$  are elements of the fuzzy set  $\tilde{F}$ , it holds that  $\exists x \mid f_1(x) = f_2(x) = y$  with  $\mu_{\tilde{F}}(f_1) \neq \mu_{\tilde{F}}(f_2)$ . When applying  $\alpha$ -discretization the fuzzy bunch of functions may be represented to advantage in the form

$$\tilde{P}(\underline{x}) = \{P_{\alpha}(\underline{x}); \mu(P_{\alpha}(\underline{x})) \mid P_{\alpha}(\underline{x}) = [P_{\min,\alpha}(\underline{x}); P_{\max,\alpha}(\underline{x})]; \mu(P_{\alpha}(\underline{x})) = \alpha \forall \alpha = (0;1]\} \quad (1)$$

In Figure 1 a cut through the fuzzy bunch at the point  $i$  is represented for the position vector  $\underline{x} = x_i$ .

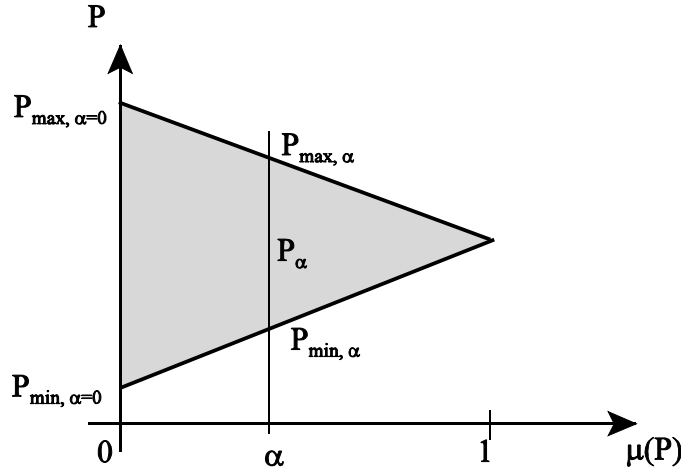

Figure 1: Cut through the fuzzy bunch at point  $i$

The fuzzy function  $\tilde{P}(\underline{x})$  is approximated by means of fuzzy values at suitably distributed interpolation nodes in  $\mathbb{R}^n$ . Fuzzy values at interpolation nodes are fuzzy numbers, which describe the fuzziness of the physical parameter concerned at discrete points  $i$ . These discrete points may be (but not necessarily) identical to nodes in the finite element mesh. The functional values at the nodes must, however, be determinable from the  $\tilde{P}(\underline{x})$ . Three fuzzy values at interpolation nodes  $x_1, x_2, x_3$  are shown in Figure 2.  $\tilde{P}(\underline{x})$  is linearly approximated between these points.

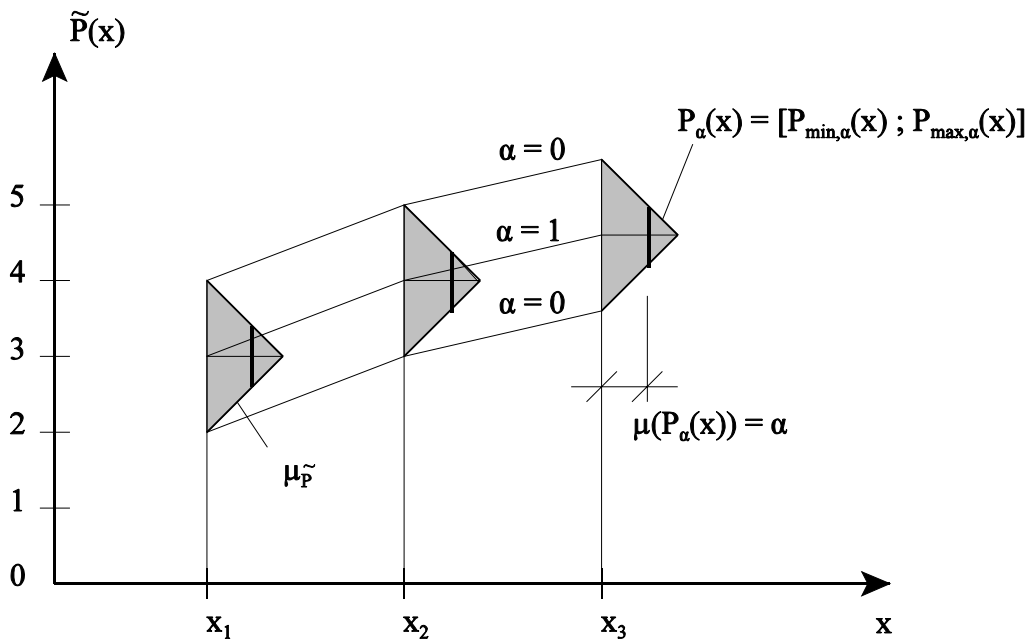

Figure 2: Approximation of the fuzzy function  $\tilde{P}(x)$  in  $\mathbb{R}^1$  using fuzzy numbers at  $x_1, x_2, x_3$

On each  $\alpha$ -level the  $P_\alpha(\underline{x})$  of Eqn. (1) may be expressed by the bunch parameter  $s_\alpha$ . For the fuzzy function  $\tilde{P}(\underline{x})$  shown in Figure 2,  $P_\alpha(x)$  between  $x_1$  and  $x_2$  may be expressed in the form

$$P_\alpha(x) = s_\alpha + m \cdot x \quad | \quad s_\alpha = [s_{\min, \alpha} ; s_{\max, \alpha}] ; \quad \forall \alpha = (0; 1] \quad (2)$$

Using the fuzzy bunch parameter  $\tilde{s}$ , the form

$$\tilde{P}(x) = \tilde{s} + m \cdot x \quad (3)$$

is also possible. The fuzzy bunch parameter  $\tilde{s}$  is shown in Figure 3.

If all fuzzy bunch parameters  $\tilde{s}_r$  are combined together in a bunch parameter vector  $\tilde{\underline{s}}$ ,  $\tilde{P}(\underline{x}, \tilde{\underline{s}})$  then holds.

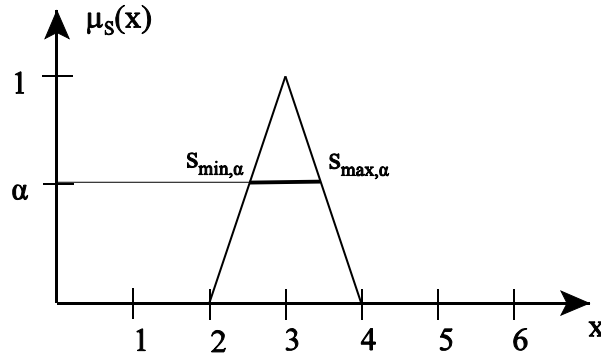

Figure 3: Fuzzy bunch parameter  $\tilde{s}$

### 3 FUZZY FINITE ELEMENTS

The introduced fuzzy functions enable fuzziness to be accounted for in the principle of virtual displacements as well as in the underlying variation principle adopted. Fuzzy extension is demonstrated here for structures in  $\mathbb{R}^1$  and  $\mathbb{R}^2$  for the principle of virtual displacements. For the position vectors  $\underline{x} = \{x_1, x_2, x_3\}$  the coordinates  $x_1$  and  $x_2$  must not exhibit fuzziness; the coordinate  $x_3$ , however, may possess fuzziness.

A displacement field  $\tilde{\underline{v}}(x)$  with fuzziness is chosen.

$$\begin{aligned} \tilde{\underline{v}}(\underline{x}) &= \underline{\mathbf{M}}(\underline{x}) \cdot \tilde{\underline{p}} && \text{with } \underline{x} = (x_1, x_2) \\ \tilde{\underline{v}}(\underline{e}) &= \underline{\mathbf{A}} \cdot \tilde{\underline{p}} \\ \tilde{\underline{p}} &= \underline{\mathbf{A}}^{-1} \cdot \tilde{\underline{v}}(\underline{e}) \\ \tilde{\underline{v}}(\underline{x}) &= \underline{\mathbf{M}}(\underline{x}) \cdot \underline{\mathbf{A}}^{-1} \cdot \tilde{\underline{v}}(\underline{e}) = \underline{\mathbf{N}}(\underline{x}) \cdot \tilde{\underline{v}}(\underline{e}) \end{aligned} \quad (4)$$

With the restriction of a linear relationship between strains and displacements, the following is obtained

$$\tilde{\underline{\epsilon}}(\underline{x}) = \underline{\mathbf{B}} \cdot \tilde{\underline{p}} = \underline{\mathbf{B}} \cdot \underline{\mathbf{A}}^{-1} \cdot \tilde{\underline{v}}(\underline{e}) = \underline{\mathbf{H}} \cdot \tilde{\underline{v}}(\underline{e}) \quad (5)$$

Moreover, a linear material law is assumed.

$$\tilde{\underline{\sigma}}(\underline{x}) = \tilde{\underline{\mathbf{E}}}(\underline{x}) \cdot \tilde{\underline{\epsilon}}(\underline{x}) = \tilde{\underline{\mathbf{E}}}(\underline{x}) \cdot \underline{\mathbf{H}} \cdot \tilde{\underline{v}}(\underline{e}) \quad (6)$$

For virtual displacements and virtual strains, the following is chosen:

$$\begin{aligned}\delta \tilde{\underline{v}}(\underline{x}) &= \underline{\mathbf{M}}(\underline{x}) \cdot \delta \tilde{\underline{p}} = \underline{\mathbf{N}}(\underline{x}) \cdot \delta \tilde{\underline{v}}(e) \\ \delta \tilde{\underline{\epsilon}}(\underline{x}) &= \underline{\mathbf{H}} \cdot \delta \tilde{\underline{v}}(e)\end{aligned}\quad (7)$$

The virtual internal fuzzy work follows from

$$\begin{aligned}\delta \tilde{A}_i &= \int_{\tilde{V}} \delta \tilde{\underline{\epsilon}}^T(\underline{x}) \cdot \tilde{\underline{\sigma}}(\underline{x}) \, d\tilde{V} \\ \delta \tilde{A}_i &= \delta \tilde{\underline{v}}^T(e) \cdot \int_{\tilde{V}} \underline{\mathbf{H}}^T \cdot \tilde{\underline{\mathbf{E}}}(\underline{x}) \cdot \underline{\mathbf{H}} \, d\tilde{V} \cdot \tilde{\underline{v}}^T(e)\end{aligned}\quad (8)$$

with the fuzzy element stiffness matrix

$$\tilde{\underline{\mathbf{K}}}(e) = \int_{\tilde{V}} \underline{\mathbf{H}}^T \cdot \tilde{\underline{\mathbf{E}}}(\underline{x}) \cdot \underline{\mathbf{H}} \, d\tilde{V}\quad (9)$$

For the virtual external fuzzy work the following holds under consideration of time-dependent fuzzy surface forces as well as mass, inertial and damping forces possessing fuzziness:

$$\begin{aligned}\delta \tilde{A}_a &= \delta \tilde{\underline{v}}^T(e) \cdot \tilde{\underline{\mathbf{F}}}(e, t) && \text{virtual work of nodal forces} \\ &+ \int_{\tilde{V}} \delta \tilde{\underline{v}}^T(\underline{x}) \cdot \tilde{\underline{\mathbf{p}}}_M(\underline{x}) \, d\tilde{V} && \text{virtual work of mass forces} \\ &+ \int_0 \delta \tilde{\underline{v}}^T(\underline{x}) \cdot \tilde{\underline{\mathbf{p}}}(\underline{x}, t) \, dA_O && \text{virtual work of time-dependent} \\ & && \text{surface forces} \\ &- \int_{\tilde{V}} \delta \tilde{\underline{v}}^T(\underline{x}) \cdot \tilde{\underline{\rho}}(\underline{x}) \cdot \tilde{\underline{v}}(\underline{x}, t) \, d\tilde{V} && \text{virtual work of inertial forces} \\ &- \int_{\tilde{V}} \delta \tilde{\underline{v}}^T(\underline{x}) \cdot \tilde{\underline{\mathbf{d}}}(\underline{x}) \cdot \tilde{\underline{v}}(\underline{x}, t) \, d\tilde{V} && \text{virtual work of damping} \\ & && \text{forces}\end{aligned}\quad (10)$$

Time  $t$  is still introduced into  $\delta \tilde{A}_a$  as a deterministic value.

Using the familiar abbreviations for element  $e$ , the following is obtained from  $\delta \tilde{A}_i - \delta \tilde{A}_a = 0$

$$\tilde{\underline{\mathbf{E}}}(e, t) = \tilde{\underline{\mathbf{F}}}(e, t) + \tilde{\underline{\mathbf{K}}}(e) \cdot \tilde{\underline{v}}(e, t) + \tilde{\underline{\mathbf{M}}}(e) \cdot \tilde{\underline{v}}(e, t) + \tilde{\underline{\mathbf{D}}}(e) \cdot \tilde{\underline{v}}(e, t)\quad (11)$$

This yields a system of second order fuzzy differential equations for the structure

$$\tilde{\underline{\mathbf{M}}} \cdot \tilde{\underline{v}} + \tilde{\underline{\mathbf{D}}} \cdot \dot{\tilde{\underline{v}}} + \tilde{\underline{\mathbf{K}}} \cdot \tilde{\underline{v}} = \tilde{\underline{\mathbf{F}}},\quad (12)$$

which, for the static case, reduces to

$$\tilde{\underline{\mathbf{K}}} \cdot \tilde{\underline{v}} = \tilde{\underline{\mathbf{F}}}\quad (13)$$

If nonlinearities are present, incremental forms must be used.

#### 4 SOLUTION TECHNIQUES

The fuzziness of the  $n_{FF}$  fuzzy functions  $\tilde{P}_k(\underline{x}, \tilde{\underline{s}})$ ,  $k = 1, 2, \dots, n_{FF}$  entering Eqns. (12) and (13) is expressed by the fuzzy elements of the bunch parameter vector  $\tilde{\underline{s}} = \{\tilde{s}_1, \tilde{s}_2, \dots, \tilde{s}_j, \dots, \tilde{s}_r\}$ . As each fuzzy function  $\tilde{P}(\underline{x}, \tilde{\underline{s}})$  consists of a bunch of crisp functions  $f$  with membership values  $\mu_p(f)$  - the originals - Eqns. (12) and (13) may be solved on an original-to-original wise by familiar methods. The two equations represent a mapping operator for each original of the form

$$\underline{v} = f(s_1, s_2, \dots, s_j, \dots, s_r). \quad (14)$$

The governing originals are determined for each  $\alpha$ -level by  $\alpha$ -level optimization<sup>2</sup>.

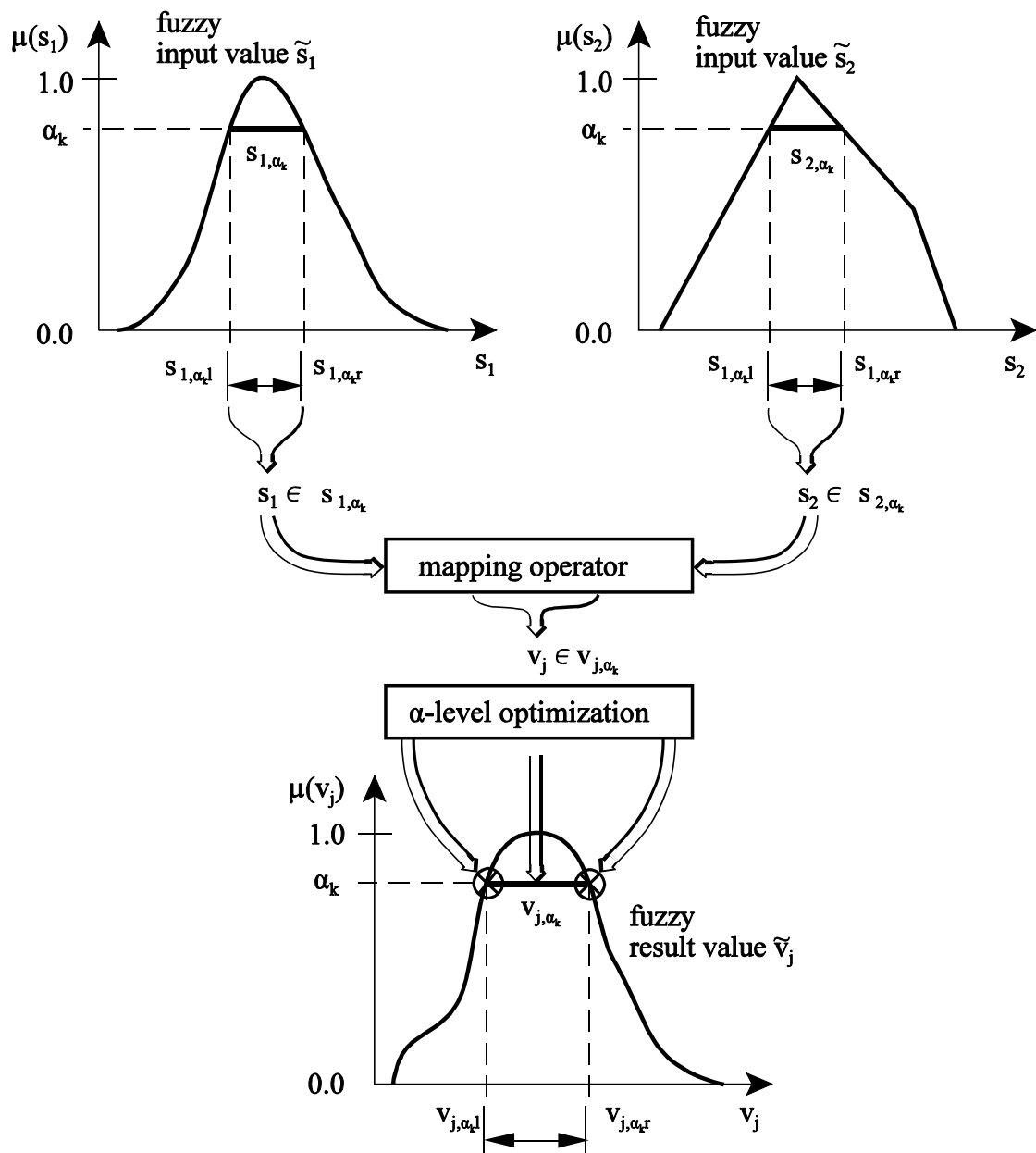

Figure 4: Mapping of the input values  $\tilde{s}_1$  and  $\tilde{s}_2$  onto the fuzzy result value  $\tilde{v}_j$

All fuzzy bunch parameters are discretized using the same number of  $\alpha$ -levels. The  $\alpha$ -level set  $s_{j, \alpha_k}$  is assigned to each bunch parameter  $\tilde{s}_j$  on the level  $\alpha_k$ , and all  $s_{j, \alpha_k}$  form the crisp subspace  $\underline{S}_{\alpha_k}$ . With the aid of the mapping operator of Eqn. (14), elements of the  $\alpha$ -level set  $v_{j, \alpha_k}$  of the fuzzy result value  $\tilde{v}_j$  may be computed on the  $\alpha$ -level  $\alpha_k$ . The mapping of all elements of  $\underline{S}_{\alpha_k}$  yields the crisp subspace  $\underline{V}_{\alpha_k}$  of the result space.

In the case of convex fuzzy result values it is sufficient to determine the largest and smallest element of the  $\alpha$ -level set  $v_{j, \alpha_k}$ . Two points of the membership function of the result value  $\tilde{v}_j$  are then known on  $\alpha$ -level  $\alpha_k$ . This method is illustrated in Figure 4 for two bunch parameters  $\tilde{s}_1$  und  $\tilde{s}_2$ .

### 5 EXAMPLE

The FFEM approach is demonstrated by way of an example. The reinforced concrete folded plate structure shown in Figure 5 is computed under consideration of the governing nonlinearities of the reinforced concrete and fuzziness associated with the superficial load, the concrete compressive strength and the position of the reinforcement.

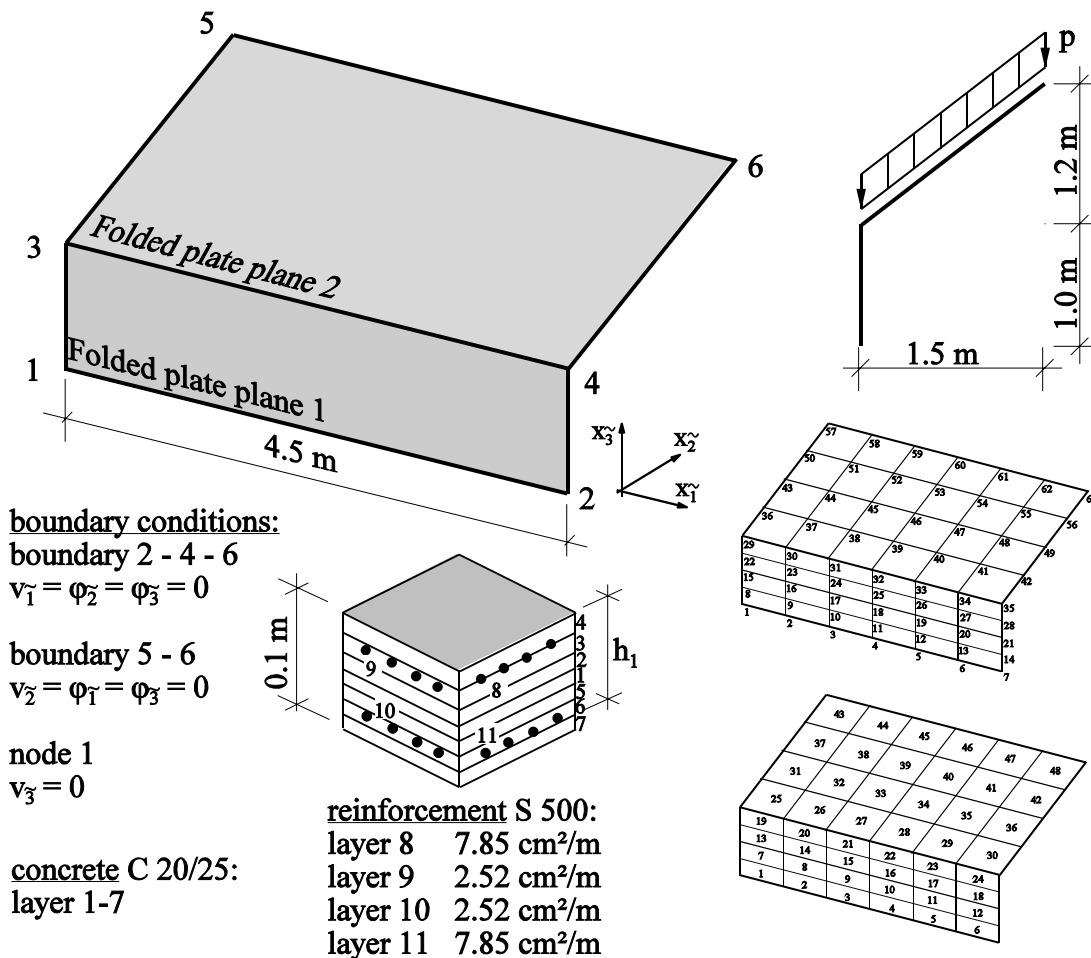

Figure 5: Geometry, finite element model

The extension for every plane of the folded plate structure in  $\mathbb{R}^2$  is crisp. The system is meshed using 48 finite elements. Each element, with an overall thickness of 10 cm, was modeled using 7 equidistant concrete layers, with two smeared mesh reinforcement layers each on the upper and lower surfaces (see Figure 5).

The concrete material law according to Kupfer/Link and a bilinear material law for reinforcement steel were applied. Tensile cracks in the concrete were accounted for in each element on a layer-to-layer basis according to the concept of smeared fixed cracks. The superficial load with fuzziness was increased incrementally up to the prescribed service load. Selected result values were computed at this stage of loading. Under consideration of the fuzziness of the uncertain input values, the result values are also fuzzy numbers.

**Investigation 1:** The superficial load and the concrete compressive strength are fuzzy input values. The superficial load is specified as a linear fuzzy function with 3 bunch parameters, which are assigned to the fuzzy values at interpolation nodes at the corners 3, 5, 6. The fuzzy values at interpolation nodes are specified by the membership function  $\mu(p)$  given in Figure 6. A crisp function from the bunch of functions is shown in Figure 6 for one  $\alpha$ -level and three values  $s_\alpha = [s_{\min, \alpha}; s_{\max, \alpha}]$ . A linear fuzzy function is also chosen for the concrete compressive strength. Assuming that each crisp function of the respective fuzzy bunch of functions describes a plane parallel to the folded plate planes 1 and 2 at the same distance from the folded plate planes, one bunch parameter is sufficient for the purposes of definition. This bunch parameter is assigned to the membership function  $\mu(\beta_R)$  (Figure 6). As an example of these results the fuzzy load- displacement dependency for the displacement  $v_3$  of node 63 under incremental load increase up to the service load ( $v = 1$ ) is shown in Figure 7.

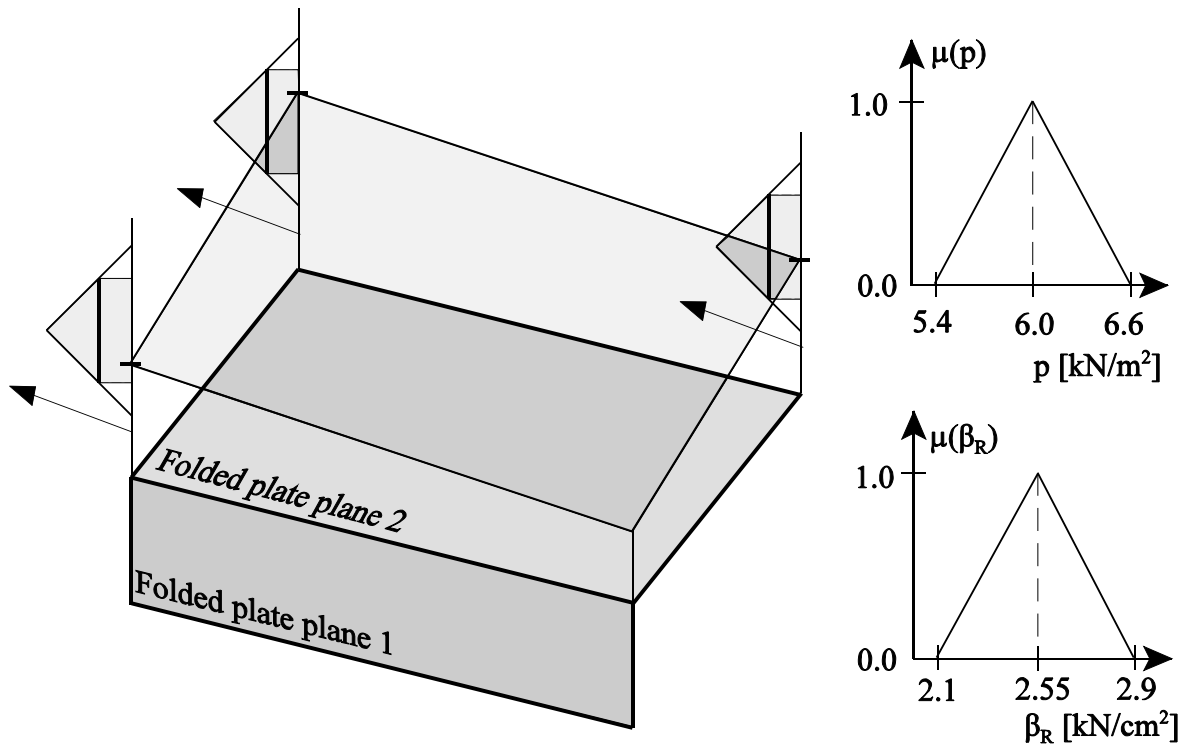

Figure 6: Fuzzy function, membership functions

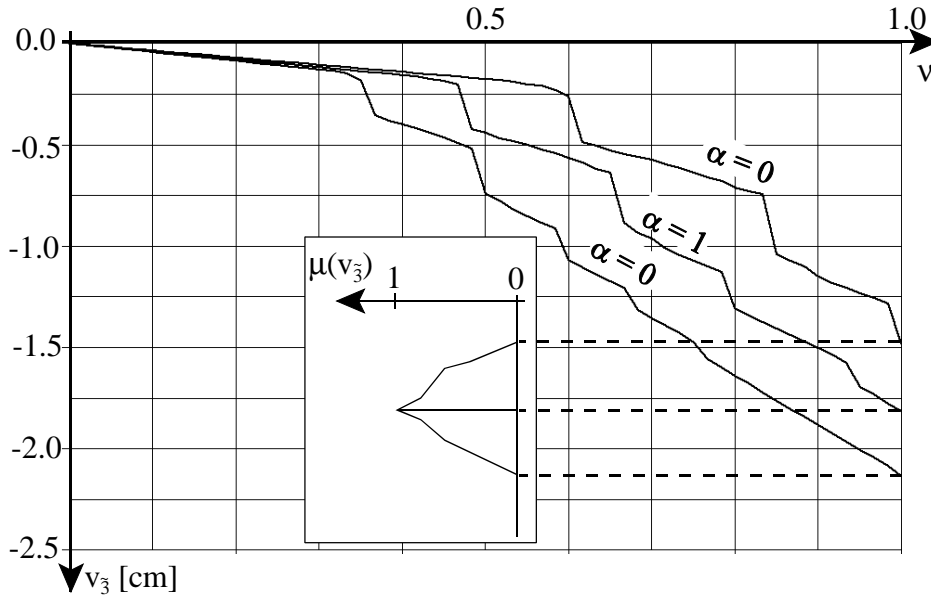

Figure 7: Fuzzy load-displacement dependency for  $v_3$  of node 63

**Investigation 2:** The fuzzy input values in this case are position of reinforcement layer 11 and the superficial load. It is also assumed for both assigned fuzzy functions that each crisp function of the fuzzy bunch of functions describes a plane parallel to plane 2 of the folded plate.

Two bunch parameters are thus required, which must be chosen from  $\mu(h_1)$  and  $\mu(p)$  (Figure 8). In this investigation the concrete compressive strength is taken to be a deterministic value equal to the value of the fuzzy bunch parameter for  $\mu(\beta_R) = 1$ . From these results the fuzzy load-displacement dependency for the displacement  $v_3$  of node 63 is presented (Figure 9).

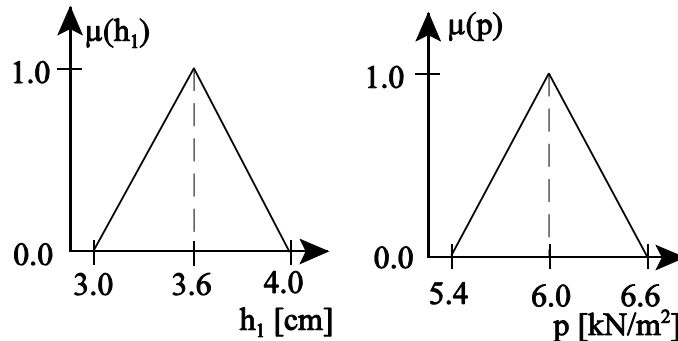

Figure 8: Membership functions of the input values

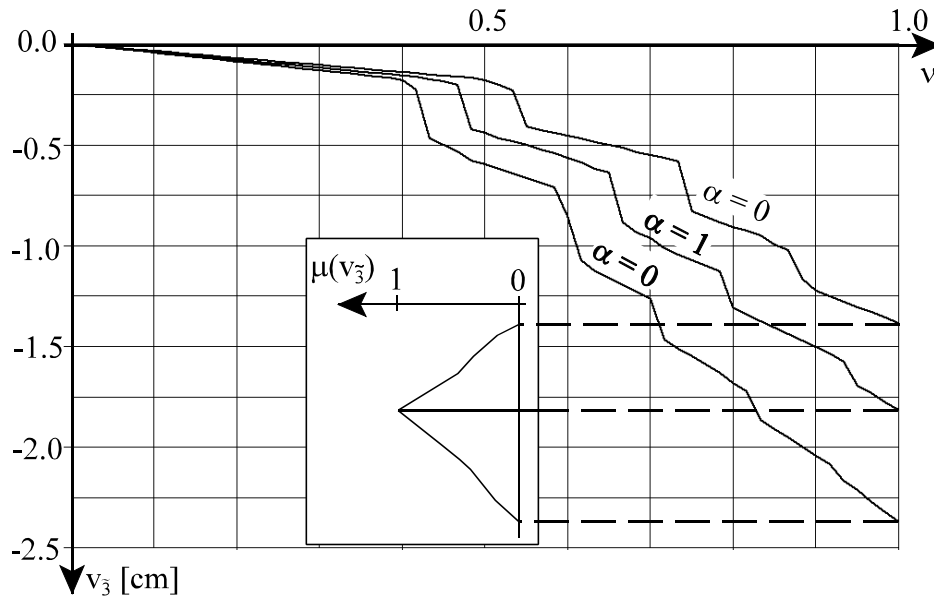

Figure 9: Fuzzy load-displacement dependency for  $v_3$  of node 63

## 6 REFERENCES

- [1] Dubois, D.; Prade, H.  
Fuzzy Sets and Systems  
Academic Press, New York, 1980
- [2] Möller, B.; Graf, W.; Beer, M.  
Fuzzy structural analysis using  $\alpha$ -level optimization  
Computational Mechanics 26 (2000) 6, 547-565
- [3] Bandemer, H.; Näther, W.  
Fuzzy Data Analysis  
Kluwer Academic Publishers, Dordrecht, 1992