

Application of fuzzy randomness to time-dependent reliability

J.-U. Sickert, W. Graf & U. Reuter

Institut für Statik und Dynamik der Tragwerke, Technische Universität Dresden, Germany

Keywords: fuzzy randomness, fuzzy random function, reliability, fuzzy Monte Carlo simulation

ABSTRACT: In the paper a new safety concept is presented considering time-dependent data uncertainty of fuzzy random type. Time-dependent data uncertainty leads to a time variant reliability of structures. The fuzzy failure probability $\tilde{P}_f(\tau)$ depending on the time τ is introduced as measure of the reliability. Based on the α -level optimization the fuzzy failure probability is computed by the fuzzy Monte Carlo simulation (FMCS). In order to decrease the numerical effort of the fuzzy Monte Carlo simulation the fuzzy adaptive importance sampling method (FAIS) is introduced. An example demonstrates the feasibility of the proposed procedure.

1 TIME-DEPENDENT RELIABILITY

The safety level of structures is not constant during the lifetime. Time variant effects such as material damage, deterioration, and corrosion lead to time variant loadability and structural safety. The consideration of these effects in the framework of a safety concept requires a material model as well as a structural model with time variant parameters. In most cases this parameters are uncertain. Using the general uncertainty model *fuzzy randomness* the time variant parameters are described as *fuzzy random processes*. If the parameters additional fluctuate in dependency of the spatial coordinates \underline{q} the mathematical model based on *fuzzy random functions* $\tilde{X}(\underline{t}) \mid \underline{t} = \{\underline{q}, \tau\}$ is adapted.

A fuzzy random function $\tilde{X}(\underline{t})$ is defined by the set of *fuzzy random vectors* on the fundamental set \mathbf{I}

$$\tilde{X}(\underline{t}) = \{ \tilde{X}_i = \tilde{X}(\underline{t}) \mid \underline{t} \in \mathbf{I} \} \quad (1)$$

A more detailed mathematical description of fuzzy random functions is contained in Sickert et al. (2003), Möller and Beer (2004), and Möller et al. (2005b).

The easiest understandable concept of safety assessment is that the reliability of structures can be calculated from the uncertain structural resistance \tilde{R} and the uncertain stress \tilde{S} . If we follow this idea and if the parameters which determine the structural resistance \tilde{R} and the stresses \tilde{S} are mathematically

described by time variant fuzzy random functions a fuzzy random resistance process $\tilde{R}(\tau)$ and a fuzzy random stress process $\tilde{S}(\tau)$ result. Using $\tilde{R}(\tau)$ and $\tilde{S}(\tau)$ the structural reliability can be quantified by the *fuzzy failure probability* \tilde{P}_f which is defined by

$$\tilde{P}_f(\tau) = P(\tilde{R}(\tau) - \tilde{S}(\tau) \leq 0) \quad (2)$$

including the well known probability measure P . The evaluation of eq. (2) requires time-discretization of $\tilde{R}(\tau)$ and $\tilde{S}(\tau)$. At each time point τ_k , $\tilde{R}(\tau_k)$ and $\tilde{S}(\tau_k)$ are obtained as fuzzy random variables which can be described by the *fuzzy probability density functions* $\tilde{f}_R(R(\tau_k))$ and $\tilde{f}_S(S(\tau_k))$. Preconditioning the independency of $\tilde{R}(\tau)$ and $\tilde{S}(\tau)$ the fuzzy failure probability can be computed using $\tilde{f}_R(R(\tau_k))$ and $\tilde{f}_S(S(\tau_k))$. Due to the definition of a fuzzy random process as fuzzy set of its original functions which are real random functions the evaluation of eq. (2) leads to the fuzzy variable $\tilde{P}_f(\tau_k)$ representing the fuzzy failure probability. The computation of $\tilde{P}_f(\tau_i)$ at different time points τ_i results a set of fuzzy variables $\tilde{P}_f(\tau_i)$. This fuzzy variables are functional values of a fuzzy process on the fundamental set \mathbf{I} , see e.g. Möller and Beer (2004).

In Fig. 1 a fuzzy random resistance process $\tilde{R}(\tau)$ and a fuzzy random stress process $\tilde{S}(\tau)$ are shown. The discontinuity of the fuzzy random resistance process $\tilde{R}(\tau)$ at time point τ_{s_i} results from e.g. rehabilitation or strengthening. As a consequence, the structural resistance increases. The uncertainty of \tilde{R}

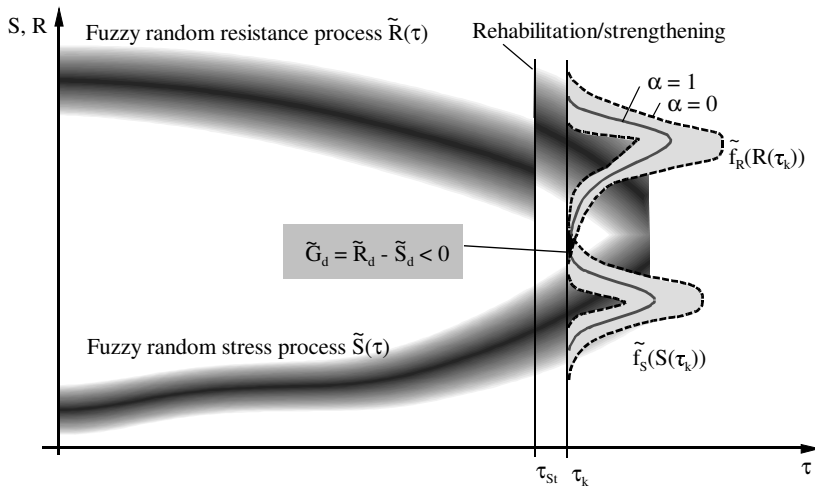

Figure 1. Fuzzy random stress-resistance-representation in time τ

and \tilde{S} at time point τ_k is represented by the assigned fuzzy probability density functions $\tilde{f}_R(R(\tau_k))$ and $\tilde{f}_S(S(\tau_k))$. The fuzzy design point \tilde{G}_d is also marked.

In the case that the structural reliability is influenced by nonlinear structural behavior the resistance depends on the stress process. Then the fuzzy failure probability $\tilde{P}_f(\tau_i)$ at time points τ_i has to be computed in the space of the fuzzy random basic variables. This space is constructed by means of the one-dimensional fuzzy random variables \tilde{X} obtained by the discretization of all fuzzy random functions $\tilde{X}(\underline{t})$. Additionally, real random variables X , e.g. as result of discretized real random functions $X(\underline{t})$, may be accounted for as basic variables at the same time. Real random variables may be regarded as special case of fuzzy random variables with only one original. The space of the fuzzy random basic variables is subdivided into a *fuzzy survival domain* \tilde{X}_s and a *fuzzy failure domain* \tilde{X}_f by the fuzzy limit state surface $\tilde{g}(\underline{x}, \underline{t}) = 0$.

Since the fuzzy probability $\tilde{P}(A_i)$ of an event A_i is defined as assessed set of the real-valued probabilities $P_j(A_i)$ the fuzzy failure probability $\tilde{P}_f(\tau_i)$ at time point τ_i have to be determined considering all significant originals $X_j \in \tilde{X}$. Each real-valued failure probability may then be computed with the aid of stochastic fundamental solutions. In principle, any probabilistic algorithm may be used as stochastic fundamental solution, e.g. first order reliability method (FORM) or Monte Carlo simulation (see e.g. Schuëller (1997)).

For each fuzzy random variable \tilde{X} which is introduced as basic variable the assigned fuzzy probability density function $\tilde{f}_X(x, \tau)$ has to be known. With the aid of the fuzzy joint probability density function $\tilde{f}_X(\underline{x}, \tau)$ the joint behavior is described considering correlation and fuzzy correlation. Both the fuzzy joint probability density functions $\tilde{f}_X(\underline{x}, \tau)$ and the fuzzy limit state surface $\tilde{g}(\underline{x}, \tau) = 0$ are fuzzy functions, which are advantageously described by means of fuzzy bunch parameters \tilde{s} and \tilde{s}_g

$$\tilde{f}_X(\underline{x}, \underline{t}) = f_X(\tilde{s}, \underline{x}) \quad (3)$$

$$\tilde{g}(\underline{x}, \underline{t}) = g(\tilde{s}_g, \underline{x}) = 0 \quad (4)$$

2 GENERATION OF FUZZY RANDOM FUNCTIONS

Time-dependent structural parameters (e.g. material parameters, geometry, loads) with the uncertainty characteristic fuzzy randomness are described by fuzzy random functions $\tilde{X}(\underline{t})$. The functions $\tilde{X}(\underline{t})$ can be stationary or non-stationary, homogeneous or non-homogeneous, Gaussian or non-Gaussian, depending on the available statistical data and additional expert knowledge. As introduced in section 1, fuzzy random functions are described by the fuzzy correlated set of fuzzy random variables $\tilde{X}_i = \tilde{X}(\underline{t}_i)$. Alternatively, fuzzy random functions can be formulated by

$$\tilde{X}(t) = f(\tilde{X}_i, t) \quad | \quad i = 1, \dots, n \quad (5)$$

where the \tilde{X}_i are fuzzy random variables. For each fuzzy random variable \tilde{X}_i the fuzzy probability distribution function $\tilde{F}_i(x)$ as well as the fuzzy probability density function $\tilde{f}_i(x)$ have to be determined. For this purpose it is necessary to determine the type and the fuzzy bunch parameters \tilde{s} of these functions.

In the case that a sample with crisp or fuzzy sample elements is available developed methods are applied for the fuzzy evaluation of statistical inference were developed which base on classical as well as modern statistics, see Möller and Beer (2004). Bootstrap methods and fuzzy Bayesian methods are also included. Moment estimators and maximum likelihood estimators are applied for point and interval estimators of the distribution parameters. Assumed distribution types are assessed with the aid of goodness-of-fit tests. Non-parametric tests for assessing samples (run test, test of homogeneity) are also applied.

If all elements of a sample are crisp the statistical evaluation in most cases is not leading to a unique result in respect of type and parameters of the underlying probability distribution function. Two concepts were developed in order to take account of this informal uncertainty - the fuzzy parameter estimation and the non-parametric estimation of the fuzzy probability distribution.

Moreover, if the sample elements are fuzzy numbers statistical methods for non-precise data are applied, see Viertl (1996).

Futhermore, probabilistic models comprehended in references can be extended in order to consider informal uncertainty and subjective influences. This will be explained by the way of an example.

In Thoft-Cristensen (1996) a probabilistic model is shown which quantifies the corrosion of reinforcement steel in concrete caused by chloride ingress. The decrease of the reinforcement steel cross section is modeled by the decrease of diameter D depending on time τ

$$D(\tau) = D_0 - 0.0232 \cdot (\tau - T_i) \cdot i_{\text{corr}} \quad (6)$$

with the original diameter D_0 , the corrosion rate i_{corr} , and the corrosion initiation time T_i . If C_{cr} is assumed to be the chloride corrosion threshold and x is the concrete cover thickness, then the corrosion initiation time T_i can be computed solving the differential equation of Fick's second law of diffusion.

$$T_i = \frac{x^2}{4D_c} \cdot \left(\text{erf}^{-1} \left(1 - \frac{C_{\text{cr}} - C_i}{C_0 - C_i} \right) \right)^{-2} \quad (7)$$

The diffusion coefficient D_c and the chloride surface content C_0 in eq. (7) are important variables in corrosion estimates. Different improved models were introduced in last decade in order to determine D_c as well as C_0 . Here, a probabilistic model based on Thoft-Christensen (1996) is extended. Both D_c and C_0 are modeled as fuzzy random variables \tilde{D}_c and \tilde{C}_0 . The chloride corrosion threshold C_{cr} , the initial chloride content C_i , and the concrete cover thickness x are assumed to be deterministic.

The mean values of the Gaussian distributed diffusion coefficient and chloride surface content are determined in dependence of the grade of deterioration G_D . As result of an inspection of a bridge experts evaluate the deterioration by the aid of a linguistic variable using the grades "low", "medium", or "high". However, the subjective assessment of different experts leads to different linguistic values G_D . Therefore, the mean values are modeled as fuzzy variables according to Fig. 2.

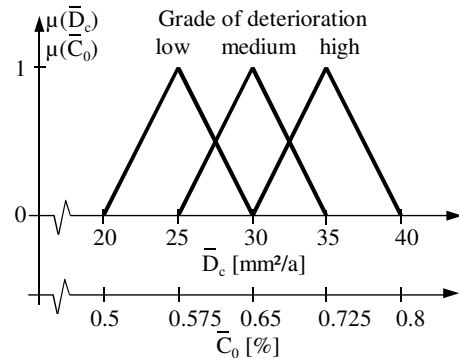

Figure 2. Membership functions of the fuzzy mean values \tilde{D}_c and \tilde{C}_0 depending on the grade of deterioration

The values with the membership $\mu = 1$ are conform to the suggestion in Thoft-Christensen (1996). Also, the standard deviation is taken from there with the deterministic values $\sigma_{D_c} = 2.5 \text{ mm}^2/\text{a}$ and $\sigma_{C_0} = 0.038 \%$. As a result of the functional dependency of \tilde{T}_i on the fuzzy random variables \tilde{D}_c and \tilde{C}_0 according to eq. (7), also, the chloride initiation time becomes a fuzzy random variable \tilde{T}_i .

Additional to \tilde{T}_i the corrosion rate i_{corr} is uncertain. Thoft-Christensen (1996) suggests to model i_{corr} as a Gaussian random variable and gives deterministic values for the coefficient of variation

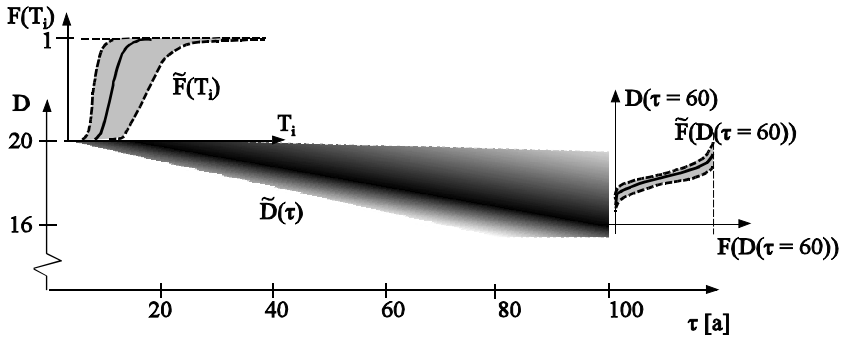

Figure 3. Fuzzy random process $\tilde{D}(\tau)$ describing the time-dependent decrease of the diameter of a reinforcement steel with original diameter $D_0 = 20$ mm

according to "typical values in normal environment". However, in most cases the evaluation of the environmental conditions by experts differs from one to another, i.e. the coefficient of variation is uncertain. Here, the corrosion rate is quantified by a Gaussian fuzzy random variable with the deterministic mean value $\bar{i}_{\text{corr}} = 2 \mu\text{A}/\text{cm}^2$ and the fuzzy standard deviation modeled by the fuzzy triangular number $\langle 0.3; 0.4; 0.5 \rangle$. The outcome of the consideration of the fuzzy random variables \tilde{i}_{corr} and \tilde{T}_i is the fuzzy random process $\tilde{D}(\tau)$ describing the time-dependent reinforcement steel diameter according to eq. (2)

$$\tilde{D}(\tau) = D_0 - 0.0232 \cdot (\tau - \tilde{T}_i) \cdot \tilde{i}_{\text{corr}} \quad (8)$$

The fuzzy random process is shown in Fig. 3. More examples you will find in Möller and Beer (2004) and Möller et al. (2005a).

3 COMPUTATION OF THE FUZZY FAILURE PROBABILITY

The fuzzy failure probability according to eq. (1) can be replaced by

$$\tilde{P}_f(\tau_k) = \int_{\mathbf{x} \mid g(\underline{s}_g, \mathbf{x}) < 0} f_{\tau_k}(\underline{s}, \mathbf{x}) d\mathbf{x} \quad (9)$$

whereby $g(\underline{s}_g, \mathbf{x}) = \tilde{R}(\tau_k) - \tilde{S}(\tau_k) \leq 0$ describes the fuzzy failure region $\tilde{X}_f(\tau = \tau_k)$ and $f_{\tau_k}(\underline{s}, \mathbf{x})$ is the fuzzy joint probability density function according to eqn. (3) and (4). For each crisp element $\underline{s} \in \tilde{\underline{s}}$ and $\underline{s}_g \in \tilde{\underline{s}}_g$ with the associated membership values $\mu(\underline{s})$ and $\mu(\underline{s}_g)$ a crisp value $P_f(\tau_k)$ of the time-dependent fuzzy failure probability is obtained. The membership values $\mu(P_f(\tau_k))$ are computed by means of the extension principle with $\mu(\underline{s}) =$

$\mu(f_{\tau_k}(\underline{s}, \mathbf{x}))$ and $\mu(\underline{s}_g) = \mu(g(\underline{s}_g, \mathbf{x}) = 0)$. In the numerical solution the extension principle is replaced by the α -level optimization.

The fuzzy failure probability is thus the fuzzy set of all values $P_f(\tau_k)$

$$\tilde{P}_f(\tau_k) = \left\{ \begin{array}{l} P_f(\tau_k), \mu(P_f(\tau_k)) \mid \\ P_f(\tau_k) = \int_{\mathbf{x} \mid g(\underline{s}_g, \mathbf{x}(\tau_k))} f_{\tau_k}(\underline{s}, \mathbf{x}) d\mathbf{x}, \\ \mu(P_f(\tau_k)) = \sup_{P_f(\tau_k)} \min[\mu(\underline{s}), \mu(\underline{s}_g)] \\ \forall \underline{s} \in \tilde{\underline{s}} \wedge \underline{s}_g \in \tilde{\underline{s}}_g \end{array} \right\} \quad (10)$$

In order to determine the time-dependent failure probability $P_f(\tau_k)$ a stochastic fundamental solution is required. In principle, any type of probabilistic algorithm may be applied for this task. In nonlinear analysis the fuzzy limit state surface $g(\underline{s}_g, \mathbf{x}) = 0$ and also each trajectory $g(\underline{s}_g, \mathbf{x}) = 0$ are nonlinear functions which can only be stated in a non-closed form. As a consequence, only simulation methods are suitable stochastic fundamental solutions. The direct Monte Carlo simulation is extended to yield the fuzzy Monte Carlo simulation (FMCS) and coupled with the fuzzy adaptive importance sampling method (FAIS) in order to improve efficiency.

3.1 Fuzzy Monte Carlo simulation (FMCS)

Fuzzy Monte Carlo simulation (FMCS) is based on α -level optimization and the direct Monte Carlo simulation. The allocation of realizations \underline{x}_i to the failure region or survival region is carried out by evaluating the fuzzy system response $\tilde{g}(\underline{x})$ using the fuzzy indicator function $I(\tilde{g}(\underline{x}))$.

$$I(\tilde{g}(\underline{x})) = \begin{cases} \{1, \mu(\tilde{g}(\underline{x})) = 0\} & \text{if } g(\underline{x}) \leq 0 \\ \{0, \mu(\tilde{g}(\underline{x})) = 0\} & \text{if } g(\underline{x}) > 0 \end{cases} \quad (11)$$

$$\forall g(\underline{x}) \in \tilde{g}(\underline{x})$$

The integral over the fuzzy failure region $g(\underline{s}_g, \underline{x}) \leq 0$ (eq. (9)) can be replaced by an integral over the entire space of the basic variables using $I(\tilde{g}(\underline{x}))$.

$$\tilde{P}_f(\tau) = \int_{-\infty}^{\infty} I(\tilde{g}(\underline{x})) \cdot f_{\tau_k}(\tilde{s}, \underline{x}) \, d\underline{x} \quad (12)$$

Eq. (12) may be interpreted as the fuzzy expected value of the indicator function $I(\tilde{g}(\underline{x}))$

$$\tilde{P}_f(\tau) = \tilde{E}[I(\tilde{g}(\underline{x}))] \quad (13)$$

Under the precondition that N realizations \underline{x}_i (simulated statistical tests) corresponding to the fuzzy joint probability density function are generated, an unbiased estimated value is obtained as follows

$$\tilde{P}_f(\tau) = \frac{1}{N} \sum_{i=1}^N I(\tilde{g}(\underline{x}_i)) \quad (14)$$

The fuzzy Monte Carlo simulation requires a very large amount of computational effort computing a small fuzzy failure probability \tilde{P} especially in connection with a nonlinear structural analysis far beyond what is realizable. It is therefore necessary to increase the efficiency of the simulation. The importance sampling method, the directional sampling method, the new method of line sampling (see Schuëller et al. (2003)), and combinations of these methods are reported in the literature (e.g. Schuëller (1997)). By way of example the extension of importance sampling to take account of fuzziness is demonstrated in the following.

3.2 Fuzzy adaptive importance sampling (FAIS)

Applying the importance sampling method that takes fuzziness into account the realizations are concentrated in the neighborhood of the most probable fuzzy failure point (fuzzy design point), as this region yields the largest contribution to the fuzzy failure probability. For this purpose the fuzzy probability integral of eq. (9) is extended by including a so-called importance density function $h(\underline{x})$.

$$\tilde{P}_f(\tau) = \int_{-\infty}^{\infty} I(\tilde{g}(\underline{x})) \cdot \frac{f_{\tau_k}(\tilde{s}, \underline{x})}{h(\underline{x})} \cdot h(\underline{x}) \, d\underline{x} \quad (15)$$

The fuzzy failure probability according to eq. (15)

corresponds to the fuzzy expected value with regard to the function $h(\underline{x})$.

$$\tilde{P}_f(\tau) = \tilde{E} \left[I(\tilde{g}(\underline{x})) \cdot \frac{f_{\tau_k}(\tilde{s}, \underline{x})}{h(\underline{x})} \right] \quad (16)$$

By simulating realizations \underline{x}_i in accordance with the importance density function $h(\underline{x})$ the fuzzy failure probability may be estimated using the unbiased estimator

$$\tilde{P}_f(\tau) = \frac{1}{N} \sum_{i=1}^N I(\tilde{g}(\underline{x}_i)) \cdot \frac{f_{\tau_k}(\tilde{s}, \underline{x}_i)}{h(\underline{x}_i)} \quad (17)$$

3.3 Numerical solution

The key of the numerical solution, i.e. the computation of the fuzzy failure probability, is the consequently used fuzzy bunch parameter representation of the fuzzy probability distribution functions and the fuzzy limit state according to eqs. (3) and (4). Following time discretization the fuzzy random variables that must be taken into consideration in the determination of $\tilde{P}_f(\tau_k)$ are specified together with the associated fuzzy probability density functions $f_{\tau_k}(\tilde{s}, \underline{x})$. The fuzzy bunch parameters $\tilde{s}_j | j = 1, \dots, r_k$ of the fuzzy probability density functions and $\tilde{s}_{g,j} | j = 1, \dots, r_g$ of the fuzzy limit state function $g(\tilde{s}_g, \underline{x}(\tau_k)) = 0$ are known. The α -discretization is applied to the $r_s = r_k + r_g$ fuzzy bunch parameters. This leads to the α -level sets $S_{1,\alpha_k}, \dots, S_{r_s,\alpha_k}$. Cartesian combination of the α -level sets $S_{1,\alpha_k}, \dots, S_{r_s,\alpha_k}$ results in an r_s -dimensional crisp subspace Δ_{α_k} for each α_k .

Each element $\underline{s} \in \Delta_{\alpha_k}$ yields a crisp failure probability, i.e. a stochastic fundamental solution. The crisp failure probability is computed in two steps. The aim of the first step is the determination of at least one point \underline{x}_i (starting points) in the failure region. In a second step the importance density function is constructed and adaptively improved.

Points \underline{x}_i in the failure region (first step) may be determined by means of a direct Monte Carlo simulation. The incremental processing of complex loading processes yields the loading level at which the structure exceeds the limit state between survival and failure. The loading level is computed under consideration of physical nonlinearities by means of an FE-model, see e.g. Möller et al 2005c. The limit state of serviceability is met when an arbitrarily prescribed restriction (e.g. for displacements, stresses, strains) is exceeded at any point of the structure during incremental proceeding of the loading process. The limit state of load-bearing

capacity is attained when an equilibrium state between external and internal forces cannot be found. The structure then exhibits global system failure. The reached ultimate load is compared with the load parameters $x_{k,i}$ specified by the Monte Carlo simulation. If the ultimate load is larger than the prescribed load parameters, the point in question lies in the survival region $\underline{x}_i \in \underline{X}_s$. If the ultimate load is smaller or equal to the prescribed load parameters, system failure occurs $\underline{x}_i \in \underline{X}_f$.

An alternative numerical solution for the determination of starting points is introduced in Möller et al. (2005a).

In the second step the multi-modal density function $h(\underline{x})$ is constructed and adaptively improved. For the computed starting point \underline{x}_i the corresponding values of the underlying probability density function $f_i(\underline{s}, \underline{x}) \in f_i(\underline{\tilde{s}}, \underline{x})$ are determined. The point \underline{x} with the largest density value is denoted by $\underline{x}^{(1)}$. The point $\underline{x}^{(1)}$ is surrounded by a hypercuboid. Multiples of the standard deviations of the associated boundary distributions hereby form the component-based dimensions of the hypercuboid. A side length of $2 \cdot 0.9 \cdot \sigma_n$ is recommended, whereby σ_n is the standard deviation of the basic variables X_n . In the case that the first step yields more than one starting point each of the points is neglected which is situated within the hypercuboid. For all remaining points without the hypercuboid the procedure is repeated and yields the representative points $\underline{x}^{(2)}$ to $\underline{x}^{(k)}$.

The importance sampling density function $h(\underline{x})$ is constructed on the basis of the representative points $\underline{x}^{(1)}$ to $\underline{x}^{(k)}$

$$h(\underline{x}) = \sum_{j=1}^k \omega^{(j)} \varphi_{X_n}^{(j)}(\underline{x}) \quad (18)$$

In eq. (18), $\varphi_{X_n}^{(j)}(\underline{x})$ represents the probability density function of the normal distribution with the expected value at the point $\underline{x}^{(j)}$, $j = 1, \dots, k$ and the standard deviation σ_n of the basic variables X_n . The choice of the importance sampling density function $h(\underline{x})$ permits a determination of the density value of $h(\underline{x})$ in a closed form.

Each probability density function $\varphi_{X_n}^{(j)}(\underline{x})$ of the multi-modal importance sampling density function $h_1(\underline{x})$ is weighted according to the value of the underlying probability distribution function $f_i(\underline{x}^{(j)})$ at the point $\underline{x}^{(j)}$.

$$\omega^{(j)} = f_i(\underline{x}^{(j)}) \cdot \left(\sum_{r=1}^k f_i(\underline{x}^{(r)}) \right)^{-1} \quad (19)$$

The weighting factor $\omega^{(j)}$ guarantees a higher

concentration of sample points \underline{x} to be generated in the governing regions for the failure probability.

The failure probability after the first iteration step is determined according to eq. (20) by simulating N_1 sample points $\underline{x}_{1,i}$ with $i = 1, 2, \dots, N_1$ in accordance with the importance sampling density function $h(\underline{x})$ given by eq. (18).

$$\hat{P}_{f_1} = \frac{1}{N_1} \sum_{i=1}^{N_1} \frac{I(g(\underline{s}, \underline{x}_{1,i})) \cdot f_i(\underline{s}, \underline{x}_{1,i})}{h_1(\underline{x}_{1,i})} \quad (20)$$

$I(g(\underline{x}_{1,i}))$ is hereby the indicator function according to eq. (11) for point $\underline{x}_{1,i}$.

The simulated sample points $\underline{x}_{1,i}$ in the failure region serve as new starting points for the second iteration step. Based on the newly-determined representative points $\underline{x}^{(1)}$ to $\underline{x}^{(k)}$ the modified importance sampling density function $h_2(\underline{x})$ is formulated in accordance with eq. (18) and new sample points $\underline{x}_{2,i}$ are simulated according to $h_2(\underline{x})$. Owing to the generation of samples according to the adaptive optimized importance sampling density functions $h_j(\underline{x})$ the influence of representative points of lesser importance with regard to the failure probability is minimized.

The failure probability \hat{P}_{f_n} after the n -th iteration step is determined according to eq. (21). The N_u sample points $\underline{x}_{u,i}$ generated in each iteration step u are taken into consideration.

$$\hat{P}_{f_n} = \frac{1}{N_{ges}} \sum_{u=1}^n \sum_{i=1}^{N_u} \frac{I(g(\underline{s}, \underline{x}_{u,i})) \cdot f_i(\underline{s}, \underline{x}_{u,i})}{\sum_{j=1}^n \frac{N_j}{N_{ges}} h_j(\underline{x}_{u,i})} \quad (21)$$

with $N_{ges} = \sum_{u=1}^n N_u$

The iteration is terminated once the convergence criterion is satisfied in five consecutive iteration steps.

$$\left(\hat{P}_{f_{n-1}} - \varepsilon \cdot \hat{P}_{f_{n-1}} \right) < \hat{P}_{f_n} < \left(\hat{P}_{f_{n-1}} + \varepsilon \cdot \hat{P}_{f_{n-1}} \right) \quad (22)$$

The tolerance value ε must be specified a-priori, e.g. $\varepsilon = 0.01$.

4 EXAMPLE

The time-dependent change of the fuzzy failure probability is demonstrated by the numerical investigation of an uniaxial RC-plate with span of 4.0 m. Three fuzzy random input parameters and additional deterministic input parameters are considered within the analysis.

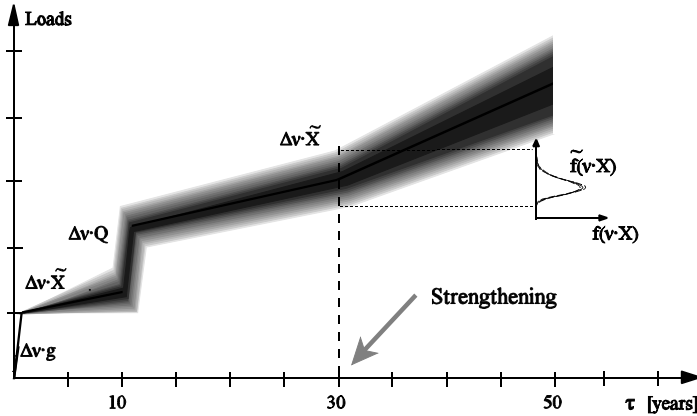

Figure 4. Fuzzy random loading process

The structural system is loaded by the loading process of Fig. 4 consisting of the dead load g , the uncertain distributed load, and the concentrated load Q . The distributed load is described by the fuzzy random function

$$\tilde{E}_1(\theta_1, \theta_2, \tau) = \tilde{X} \cdot v(\tau) \quad (23)$$

Due to the perfect correlation the fuzzy random variable \tilde{X} is independent of the space coordinates θ_1 and θ_2 . \tilde{X} is modeled by logarithmic normal distribution (expected value $E[\tilde{X}] = 5 \text{ kN/m}^2$, fuzzy standard deviation $\tilde{\sigma}_X = \sqrt{\text{VAR}[\tilde{X}]} = \tilde{s}_1$, $\tilde{s}_1 = \langle 0.75; 0.8; 0.85 \rangle \text{ kN/m}^2$ as fuzzy bunch parameter). Because of the independence of the expected value and the standard deviation of \underline{t} the fuzzy random function $\tilde{E}_1(\theta_1, \theta_2, \tau)$ according eq. (23) is stationary in wide sense.

The tensile and compressive strength of concrete \tilde{f}_{ctm} , $\tilde{f}_{cm,cyl}$ are additional fuzzy random input parameters. The correlated, Gaussian fuzzy random function

$$\tilde{E}_2(\theta_1, \theta_2, \tau) = \tilde{f}_{cm,cyl}(\theta_1, \theta_2) \quad (24)$$

is introduced in order to describe the fluctuations of the concrete compressive strength in the space (expected value $E[\tilde{f}_{cm,cyl}] = 20 \text{ N/mm}^2$, fuzzy standard deviation $\tilde{\sigma}_f = \sqrt{\text{VAR}[\tilde{f}_{cm,cyl}]} = \tilde{s}_2$, $\tilde{s}_2 = \langle 1.9; 2.0; 2.1 \rangle \text{ N/mm}^2$ as second fuzzy bunch parameter). Moreover, perfect correlation exists between \tilde{f}_{ctm} and $\tilde{f}_{cm,cyl}$ due to the used endochronic material law. Structural damage is also considered within the endochronic material law. Tensile cracks in concrete are accounted for in each element on a layer-to-layer basis according to

the concept of smeared fixed cracks.

The RC-plate was strengthened after a time period of 30 years. In the deterministic computation model based on the multi-reference plane model (see Möller et al. (2005c)) the layers of the old structure (reference plane 1) and the layers of the textile reinforced finegrade concrete (reference plane 2) are kinematically connected with the aid of an interface of thickness zero, see Fig. 5.

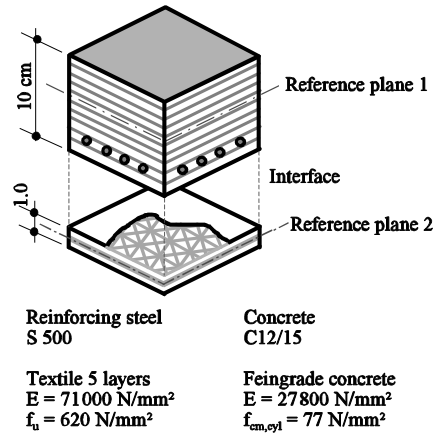

Figure 5. Multi-reference plane model

The time-dependent fuzzy failure probability $\tilde{P}_f(\tau)$ is computed using the FAIS algorithm under consideration of the governing nonlinearities of reinforced concrete.

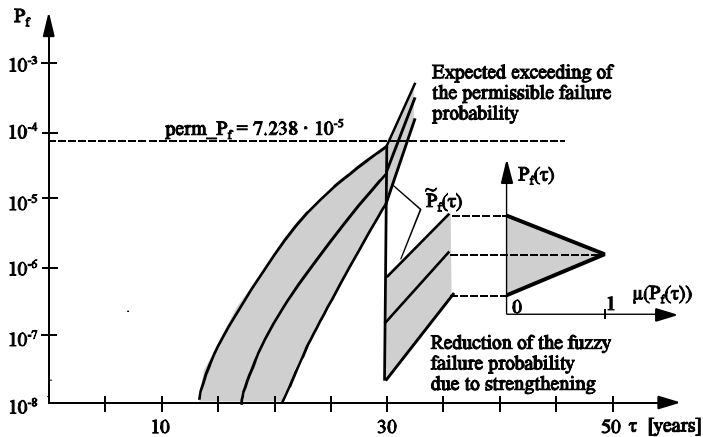

Figure 6. Time-dependent fuzzy safety level specified by the fuzzy function $\tilde{P}_f(\tau)$

The fuzzy function $\tilde{P}_f(\tau)$ of the unstrengthened and the textile strengthened RC-plate is shown in Fig. 6.

The required time point of strengthening follows by comparing the fuzzy failure probability P_f of the unstrengthened RC-plate with the permissible failure probability, e.g. for the ultimate limit state $\text{perm}_P_f = 7.328 \cdot 10^{-5}$. These permissible failure probability is equivalent to the reliability index $\beta = 3.8$.

ACKNOWLEDGMENTS

The authors gratefully acknowledge the support of the German Research Foundation (DFG).

REFERENCES

- Mahadevan, S. & Ragothamachar, P. 2000. Adaptive simulation for system reliability analysis of large structures. *Comp. & Struct.* 77(2000) 725-734
- Möller, B. & Beer, M. 2004. *Fuzzy Randomness - Uncertainty in Civil Engineering and Computational Mechanics*. Berlin Heidelberg New York: Springer
- Möller, B., Beer, M., Graf, W. & Sickert, J.-U. 2005a. Time-dependent reliability of textile-strengthened RC structures under consideration of fuzzy randomness. *Comp. & Struct.* (submitted)
- Möller, B., Beer, M. & Reuter, U. 2005b. Theoretical Basics of Fuzzy-Randomness - Application to time series with fuzzy data. *9th Int. Conf. On Structural Safety And Reliability, Rome* (accepted)
- Möller, B., Graf, W. Hoffmann, A. & Steinigen, F. 2005c. Numerical simulation of structures with textile reinforcement. *Comp. & Struct.* (in print)
- Schuëller, G.I. (Ed.) 1997. A state-of-the-Art Report on Computational Stochastic Mechanics. *Probabilistic Engineering Mechanics* 12(4)(1997) 197-321
- Schuëller, G.I., Pradlwarter, H.J. & Koutsourelakis, P.S. 2003. A comparative study of reliability estimation procedures for high dimensions. *16th ASCE Engineering Mechanics Conference*, Seattle, CD-ROM
- Sickert, J.-U., Beer, M., Graf, W. & Möller, B. 2003. Fuzzy Probabilistic Structural Analysis considering Fuzzy Random Functions. *9th Int. Conf. on Applications of Statistics and Probability in Civil Engineering - ICASP 9 San Francisco*, Rotterdam: Milpress: 379-386
- Thoft-Christensen, P. 1996. Reliability profiles for concrete bridges. *Proceedings of the Workshop on Structural Reliability in Bridge Engineering*, University of Colorado Boulder, 239-244
- Viertl, R. 1996. *Statistical Methods for Non-Precise Data*. Boca Raton New York London Tokyo: CRC Press